

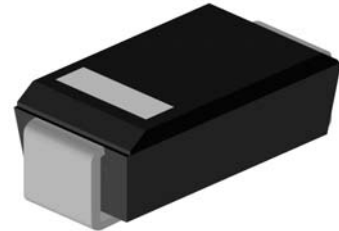

Zener diode

Features

1. For surface mounted applications
2. Low zener impedance
3. Low regulation factor
4. V_Z -tolerance $\pm 5\%$



Applications

Voltage stabilization

Absolute Maximum Ratings

$T_j=25^\circ\text{C}$

Parameter	Test Conditions	Type	Symbol	Value	Unit
Power dissipation	$T_{\text{amb}} \leq 50^\circ\text{C}$		P_V	1.5	W
Z-current			I_Z	P_V/V_Z	mA
Junction temperature			T_j	150	$^\circ\text{C}$
Storage temperature range			T_{stg}	-65~+175	$^\circ\text{C}$

Maximum Thermal Resistance

$T_j=25^\circ\text{C}$

Parameter	Test Conditions	Symbol	Value	Unit
Junction ambient	$l=9.5\text{mm}(3/8")$ $T_L=\text{constant}$	R_{thJA}	100	K/W

Stresses exceeding maximum ratings may damage the device. Maximum ratings are stress ratings only. Functional operation above the recommended operating conditions is not implied. Extended exposure to stresses above the recommended operating conditions may affect device reliability.

Electrical Characteristics

$T_j=25^\circ\text{C}$

Parameter	Test Conditions	Type	Symbol	Min	Typ	Max	Unit
Forward voltage	$I_F=200\text{mA}$		V_F			1.5	V

Excel Semiconductor



Type	Device marking	$V_{Znom}^{1)}$	I_{ZT}	for	r_{zT}	r_{zK}	at	I_{ZK}	I_R	at	V_R
		V	mA		Ω	Ω		mA	μA	V	
SMA5913B	5913B	3.3	113.6		<10	<500		1	<50		1
SMA5914B	5914B	3.6	104.2		<9	<500		1	<35.5		1
SMA5915B	5915B	3.9	96.1		<7.5	<500		1	<12.5		1
SMA5916B	5916B	4.3	87.2		<6	<500		1	<2.5		1
SMA5917B	5917B	4.7	79.8		<5	<500		1	<2.5		1.5
SMA5918B	5918B	5.1	73.5		<4	<350		1	<2.5		2
SMA5919B	5919B	5.6	66.9		<2	<250		1	<2.5		3
SMA5920B	5920B	6.2	60.5		<2	<200		1	<2.5		4
SMA5921B	5921B	6.8	55.1		<2.5	<200		1	<2.5		5.2
SMA5922B	5922B	7.5	50		<3	<400		0.5	<2.5		6
SMA5923B	5923B	8.2	45.7		<3.5	<400		0.5	<2.5		6.5
SMA5924B	5924B	9.1	41.2		<4	<500		0.5	<2.5		7
SMA5925B	5925B	10	37.5		<4.5	<500		0.25	<2.5		8
SMA5926B	5926B	11	34.1		<5.5	<550		0.25	<0.5		8.4
SMA5927B	5927B	12	31.2		<6.5	<550		0.25	<0.5		9.1
SMA5928B	5928B	13	28.8		<7	<550		0.25	<0.5		9.9
SMA5929B	5929B	15	25		<9	<600		0.25	<0.5		11.4
SMA5930B	5930B	16	23.4		<10	<600		0.25	<0.5		12.2
SMA5931B	5931B	18	20.8		<12	<650		0.25	<0.5		13.7
SMA5932B	5932B	20	18.7		<14	<650		0.25	<0.5		15.2
SMA5933B	5933B	22	17		<17.5	<650		0.25	<0.5		16.7
SMA5934B	5934B	24	15.6		<19	<700		0.25	<0.5		18.2
SMA5935B	5935B	27	13.9		<23	<700		0.25	<0.5		20.6
SMA5936B	5936B	30	12.5		<26	<750		0.25	<0.5		22.8
SMA5937B	5937B	33	11.4		<33	<800		0.25	<0.5		25.1
SMA5938B	5938B	36	10.4		<38	<850		0.25	<0.5		27.4
SMA5939B	5939B	39	9.6		<45	<900		0.25	<0.5		29.7
SMA5940B	5940B	43	8.7		<53	<950		0.25	<0.5		32.7
SMA5941B	5941B	47	8		<67	<1000		0.25	<0.5		35.8
SMA5942B	5942B	51	7.3		<70	<1100		0.25	<0.5		38.8

1) Based on DC-measurement at thermal equilibrium while maintaining the lead temperature(T_L)at 30°C, 9.5mm(3/8") from the diode body.



Characteristics ($T_j=25^\circ\text{C}$ unless otherwise specified)

Symbol	Parameter
V_Z	Reverse zener voltage @ I_{ZT}
I_{ZT}	Reverse current
Z_{ZT}	Maximum zener impedance @ I_{ZT}
I_{ZK}	Reverse current
Z_{ZK}	Maximum zener impedance @ I_{ZK}
I_R	Reverse leakage current @ V_R
V_R	Breakdown voltage
I_F	Forward current
V_F	Forward voltage @ I_F

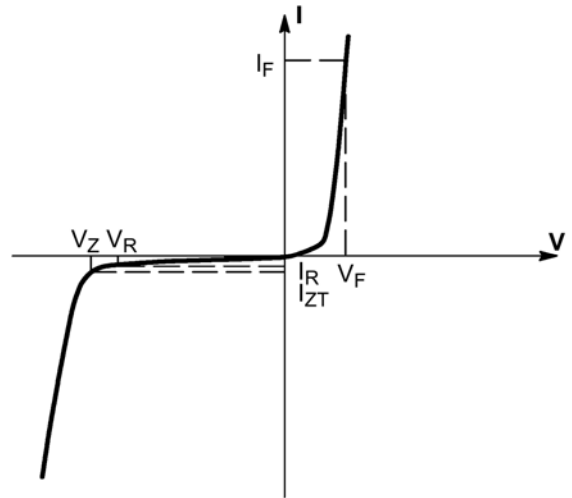

Figure 1. Zener voltage regulator

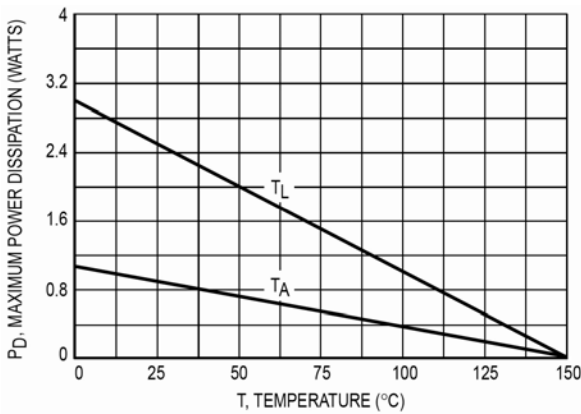

Figure 2. Steady state power derating

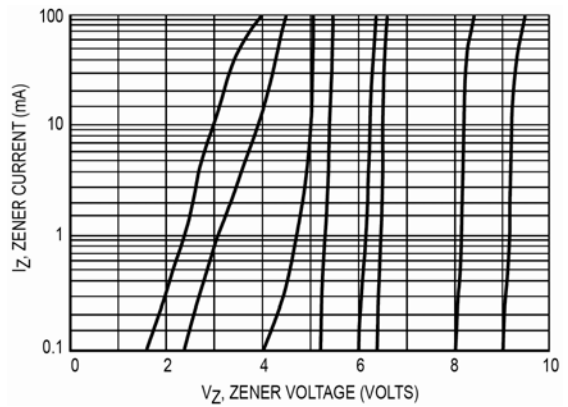

Figure 3. V_Z - 3.3 thru 10 volts

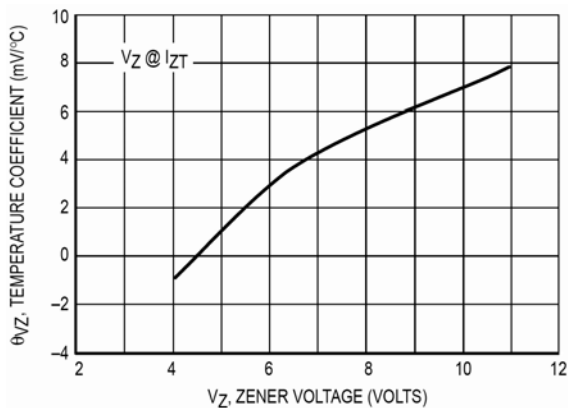

Figure 4. Zener voltage - 3.3 to 12 volts

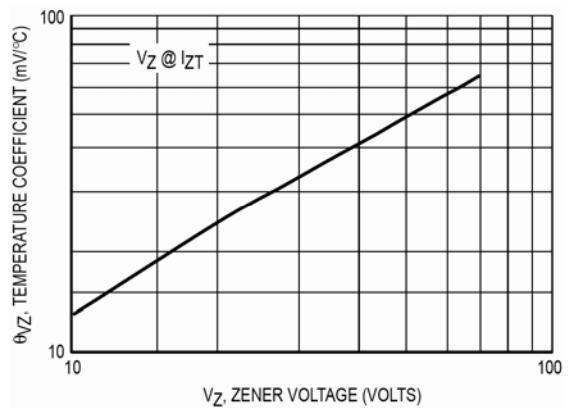

Figure 5. Zener voltage - 14 to 43 volts

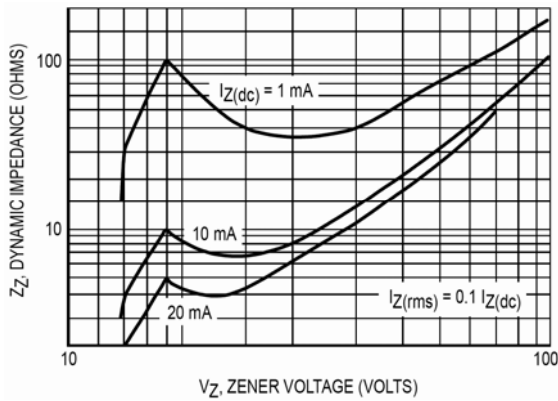

Figure 6. Effect of zener voltage

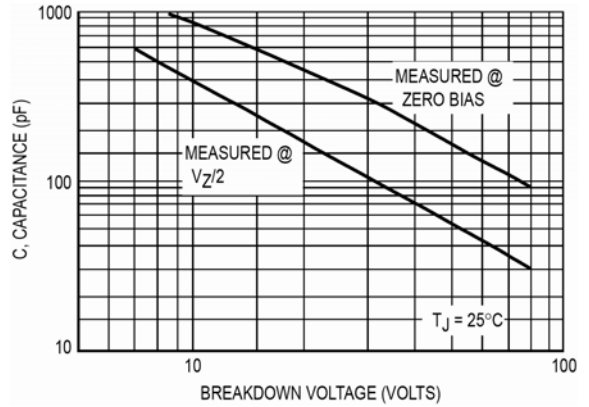

Figure 7. Capacitance curve

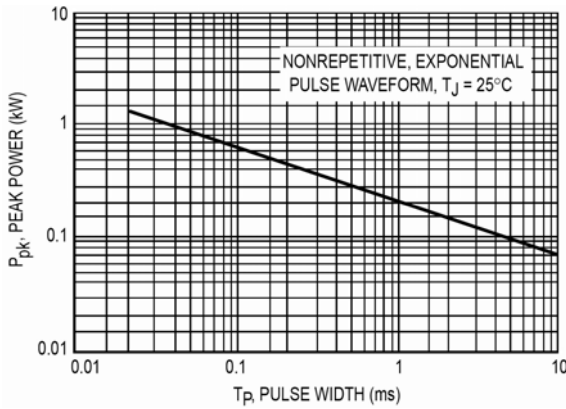

Figure 8. Typical pulse rating curve

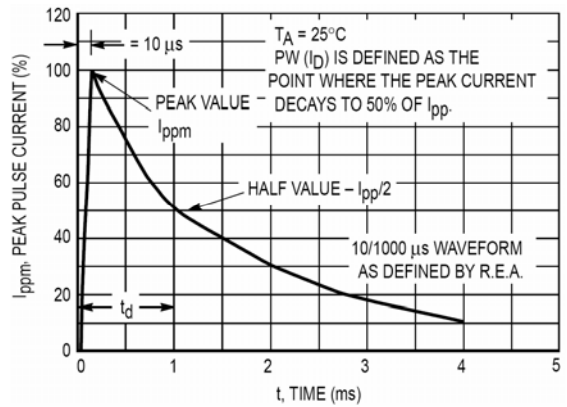

Figure 9. Pulse waveform

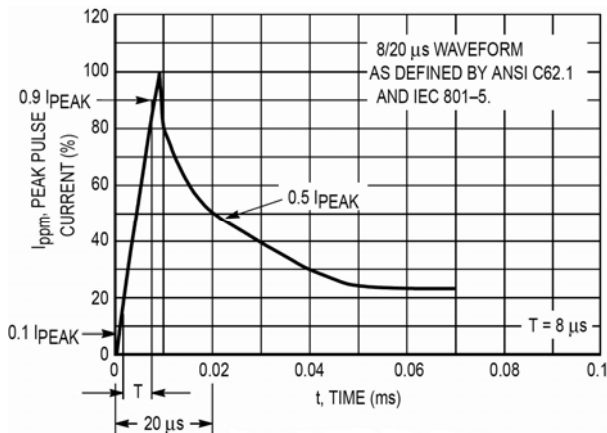
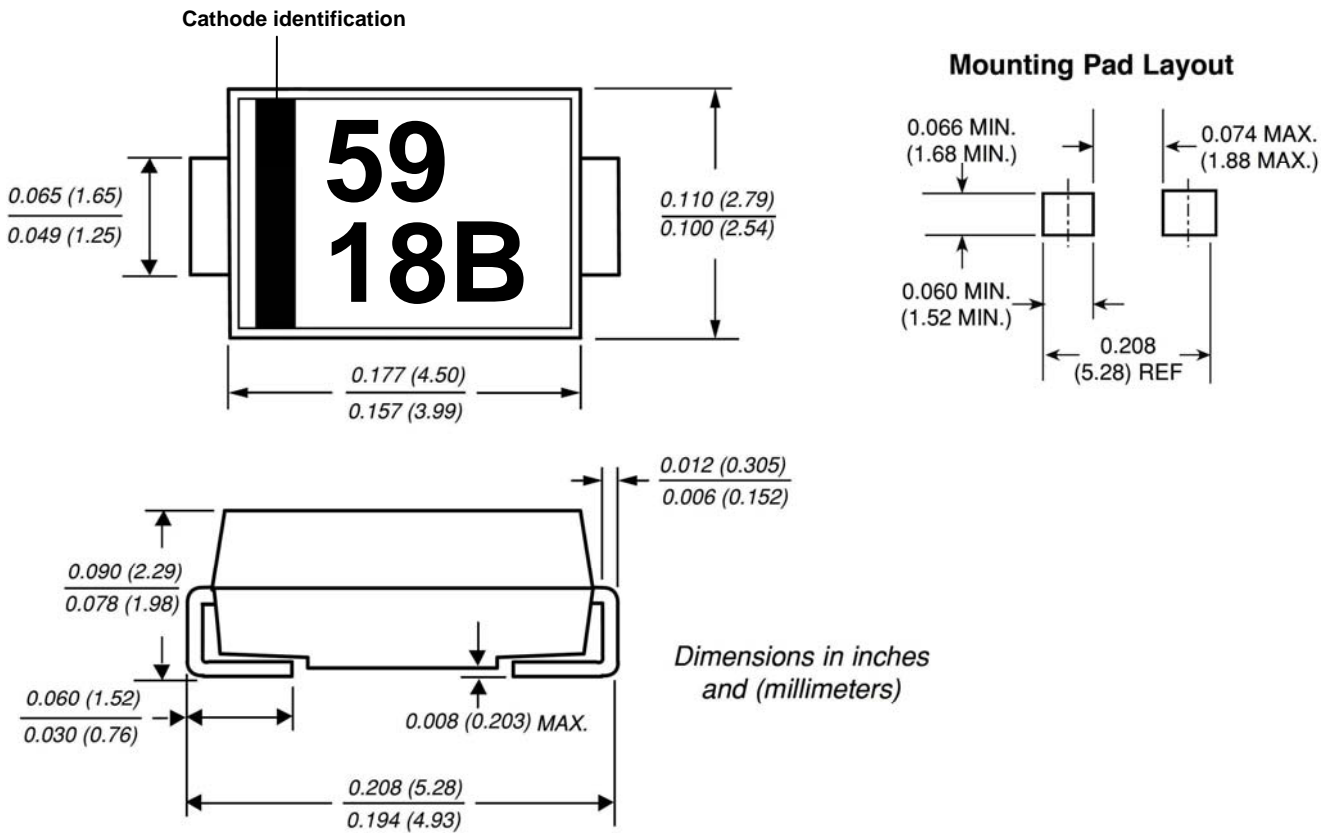

Figure 10. Pulse waveform



Dimensions in inches (mm)



DO-214AC (SMA)